

1662 Hole Cutter

Operation & Service Manual

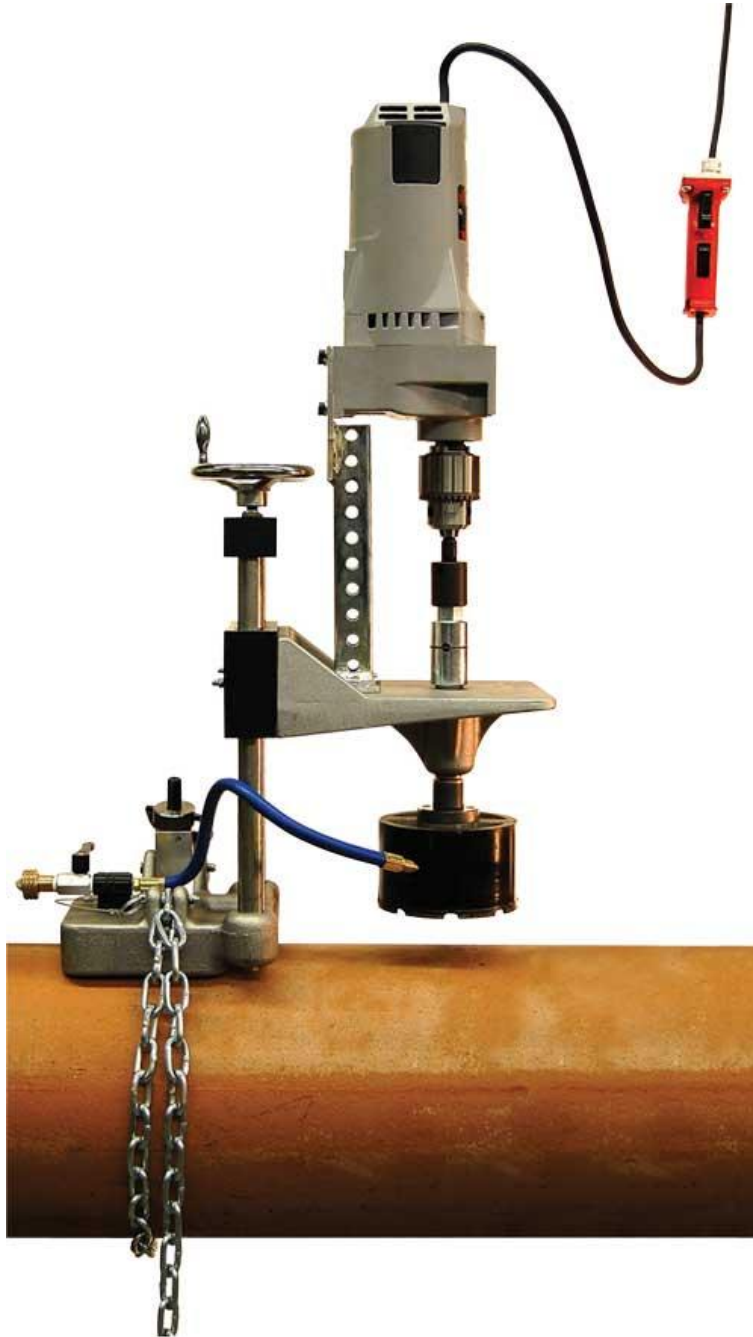

Wheeler-Rex • Ashtabula, Ohio
Tel: 800-321-7950 • Fax: 440-992-2925
wheeler@wheelerrex.com • www.wheelerrex.com

November 2012

Choosing the Shell Cutter

There are three different types of shell cutters.



For Clay and Concrete

Nominal Hole Size	Part No.
4"	3395
4 1/2"	3450
6"	3595
6 1/2"	3650



**For Reinforced Concrete,
Clay, Ductile Iron and Cast Iron**

Nominal Hole Size	Part No.
4"	6395
4 1/2"	6450
6"	6595
6 1/2"	6650
8"	6800



For Plastic

Nominal Hole Size	Part No.
4"	4395
4 1/2"	4450
6"	4595
6 1/2"	4650
8"	4800

Changing the Shell Cutter



Remove the two (2) screws from the arbor.



Loosen the set screw with the Allen key and insert pilot drill. Make sure pilot drill is aligned for the set screw to tighten on drill flat.



Attach the shell cutter with the two (2) screws.

** Shell cutters & pilot drill are sold separately from the hole cutter unit.**

Hole Cutter Setup



Set the hole cutter on the pipe.

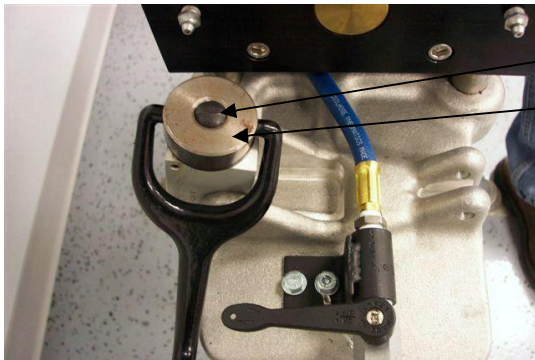

Screw

Nut

Unscrew hand clamp until screw is flush with nut.



Make sure the pipe is nested properly in the saddle of the base casting. Pull chain under pipe and back to casting base. Place one chain link between casting and push pin through base and chain link. Tighten chain with hand crank.

Preparing for the Cut

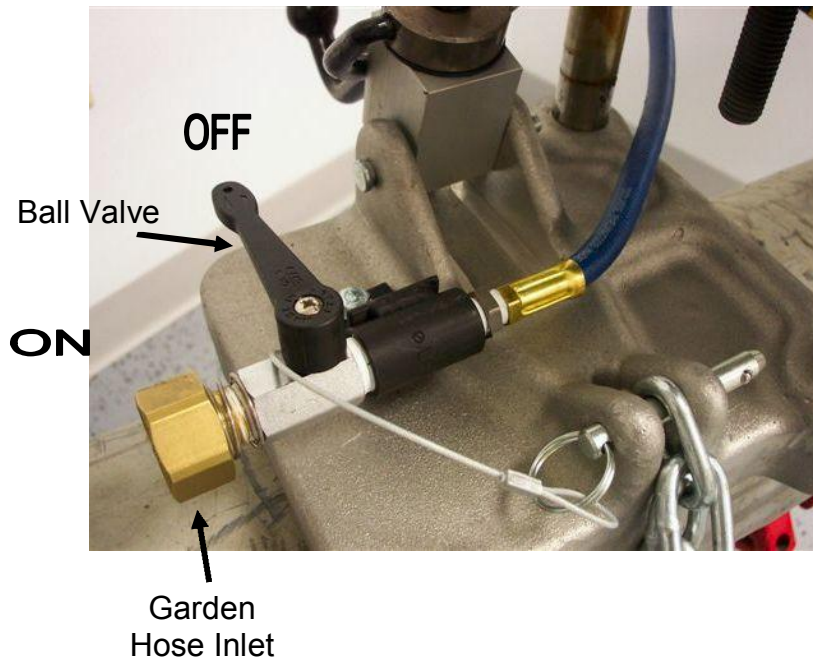

Attach garden hose to valve connection. Turn water on at source. Keep ball valve "OFF" until ready to make cut. This ball valve can also be used to control the water flow.



Adjust flexible hose for water stream to point on shell cutter. This is to help keep the cutter cool as well as flush away chips.

Making the Cut

1. Turn fluid valve to “ON” position.
2. Pull handle trigger on power cord for power.

3.



Slowly turn feed hand wheel in the clockwise position to lower the shell cutter. A heavy feed rate may damage shell cutter or pipe that is being cut. Allow shell cutter to cut material with a slow, steady turn of the feed wheel. If at anytime there are problems making the cut, stop cutting immediately.

Other Options

The hole cutter is a modular system where the base, feed mechanism and arbor assembly remain the same. The power supply is interchangeable with four different options: Electric, gas, pneumatic, and hydraulic.

Here is how to change power supplies:

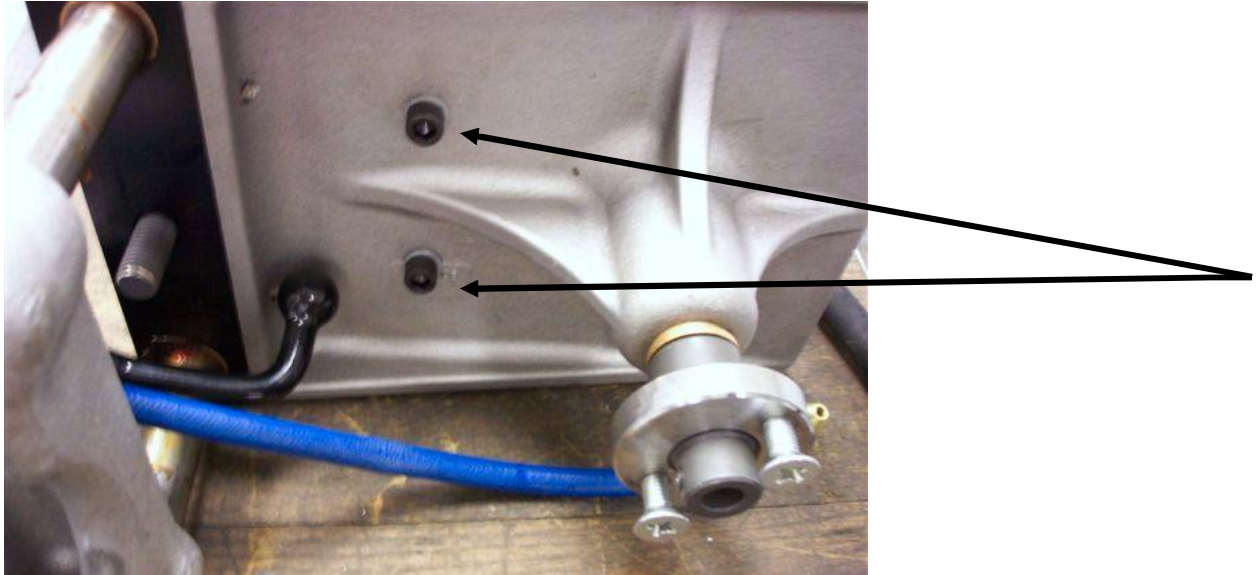

Remove the two (2) socket head cap screws from the platform.

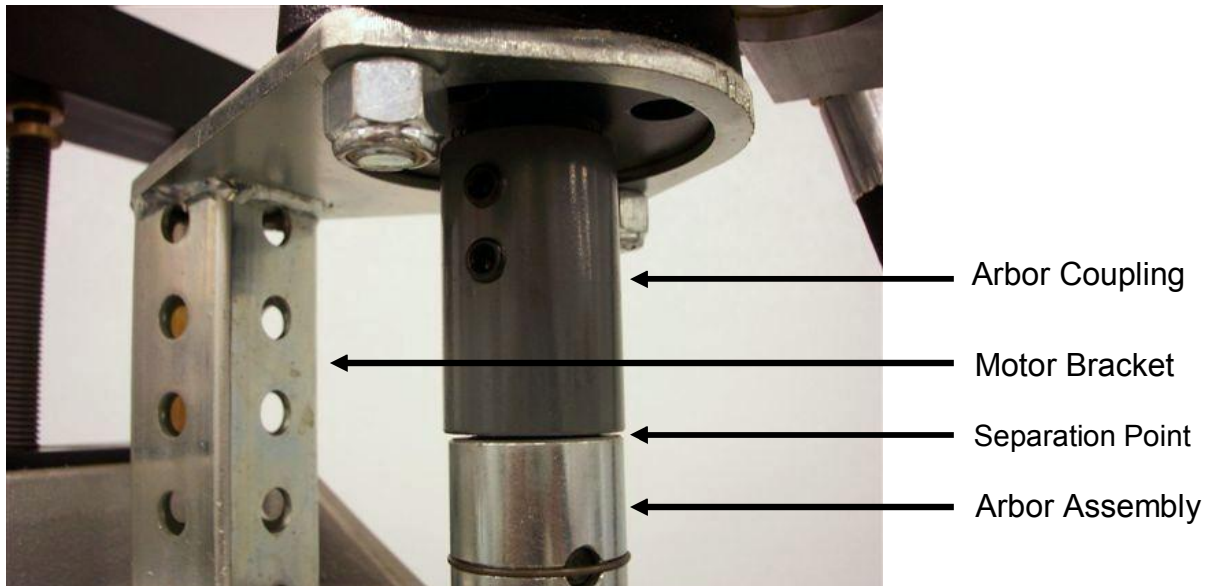

Separate the motor assembly from the arbor assembly. You can now replace the power assembly.

Maintenance

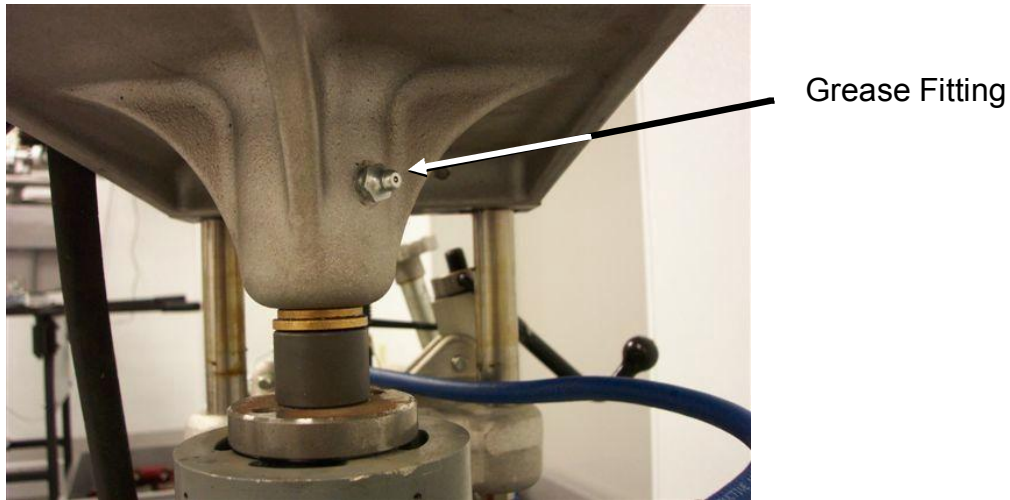

Grease arbor shaft prior to each use.

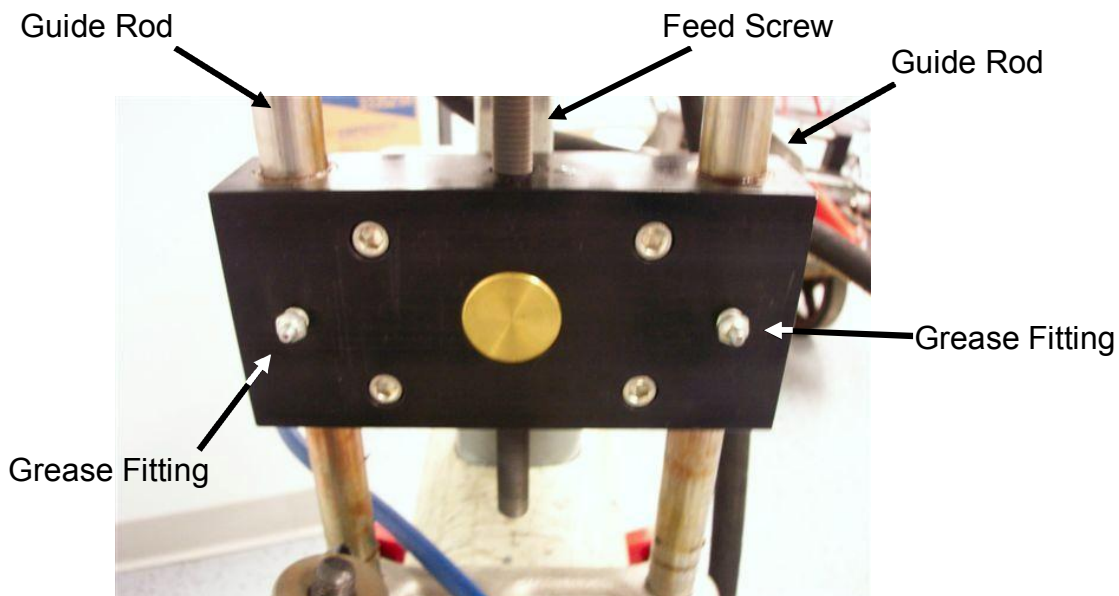

Grease guide rod bushings prior to each use. Clean guide rods after each use. Clean feed screw before and after each use.

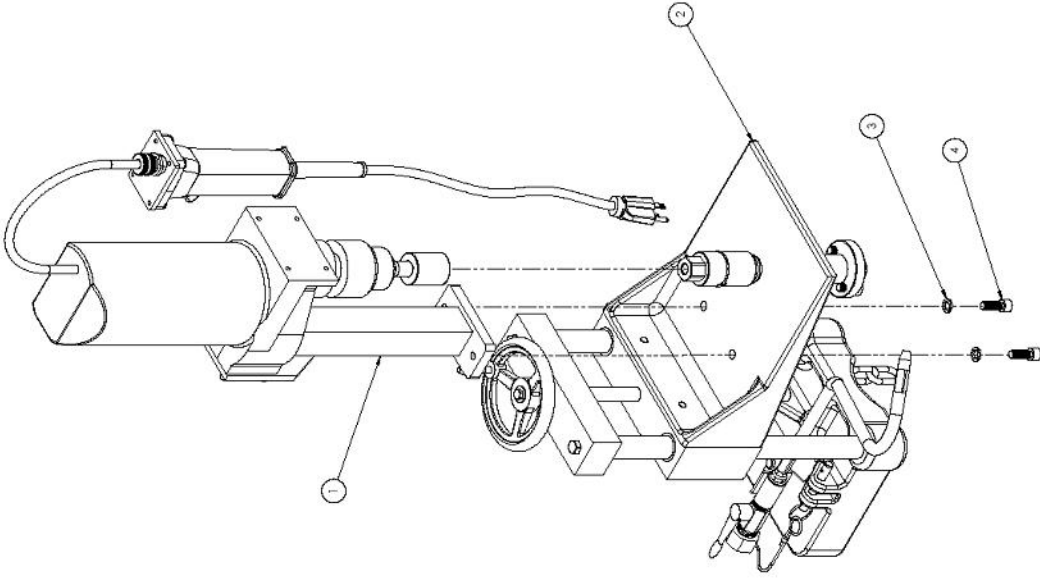

3744 JAMESON RD., APTOS, CA 95025
 DESCRIPTION: ELECTRIC HOLE CUTTER
 PART NO. 1662

ITEM NO.	PART NUMBER	DESCRIPTION	QTY
1	700456	ELECTRIC MOTOR & MOUNT ASSEMBLY	1
2	700420	HOLE CUTTER ASSEMBLY	1
3	7179	3/8" SPLIT LOCK WASHER	2
4	275118	3/8-16 x 1" SOCKET HEAD CAP SCREW	2

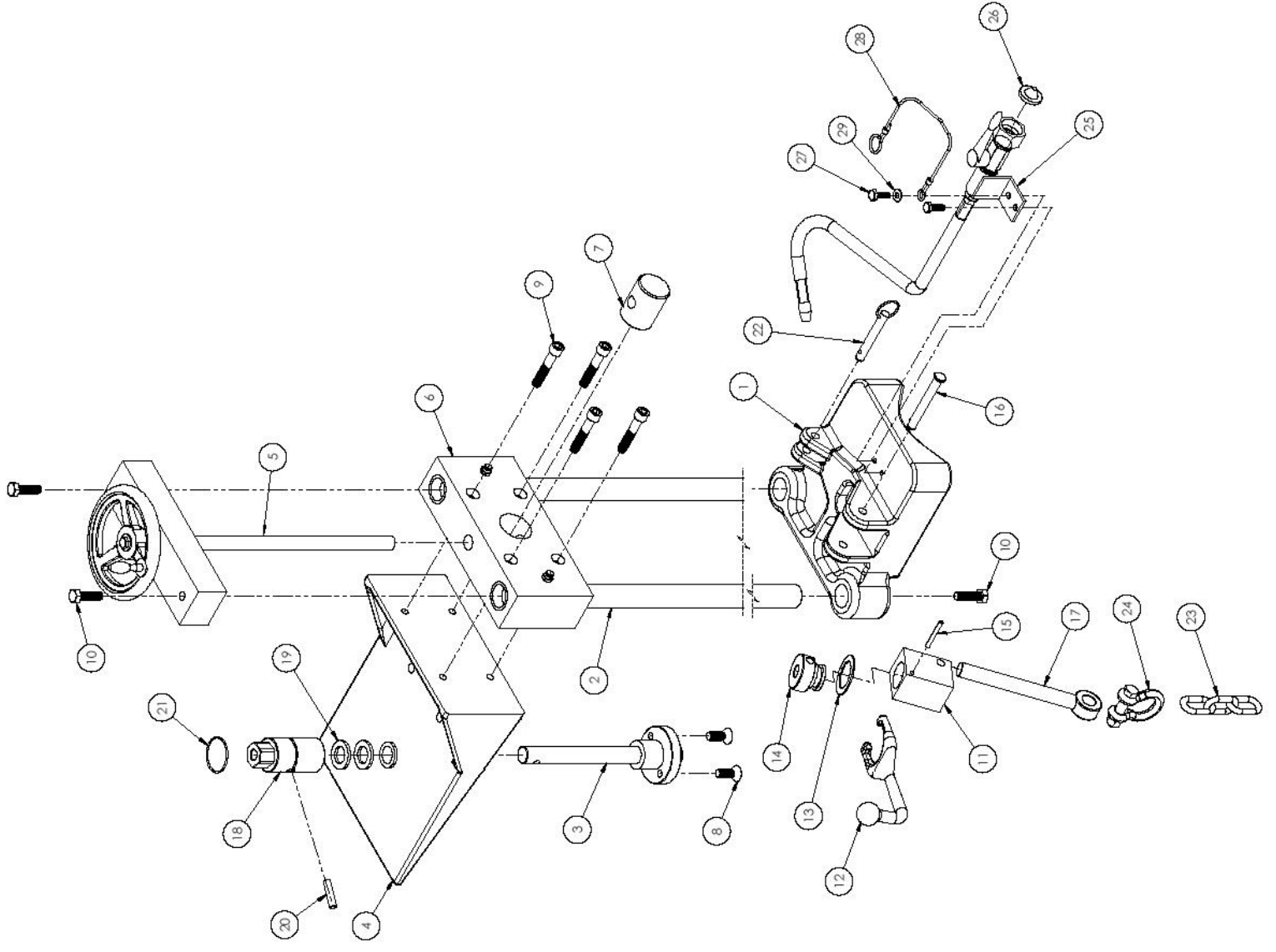

Item	PN	Description	Qty
1	700991	Base (MACHINED)	1
2	700431	ROD	2
3	700443	ARBOR ASSEMBLY	1
4	700441	ARBOR HOUSING ASSEMBLY	1
5	700438	HEAD ASSEMBLY	1
6	700433	ELEVATOR ASSEMBLY	1
7	700436	DRIVE BLOCK	1
8	12011	3/8-16 x 1" PHILLIPS FLAT HEAD MACHINE SCREW	2
9	276547	3/8-16 x 2" SHCS	4
10	276541	3/8-16 x 1 1/4" SS HEX HEAD CAP SCREW	4
11	700985	CHAIN TENSION BLOCK	1
12	606742	HANDLE	1
13	606751	BEARING	1
14	700989	CRANK NUT	1
15	275862	3/16" DIA x 1 1/2" ROLL PIN	1
16	276892	COTTERLESS CLEVIS PIN 3/8" x 3" LONG	1
17	276592	5/8-11 x 6" FULLY THREADED EYE BOLT	1
18	700445	BORING CAP	1
19	276481	THRUST BEARING (ST 2440-4)	2
20	276097	DOWEL PIN	1
21	260	CAP PIN RETAINER	1
22	276891	3/8" x 2" LONG DETENT PIN	1
23	700397	6' LONG CHAIN	1
24	276591	3/8" x 1" CHAIN SHACKLE	1
25	701079	FLUID ASSEMBLY	1
26	275917	STRAINER	1
27	560081	1/4-20 x 3/4" HHCS	2
28	276073	6" LANYARD	1
29	10713	3/16" FLAT WASHER	1

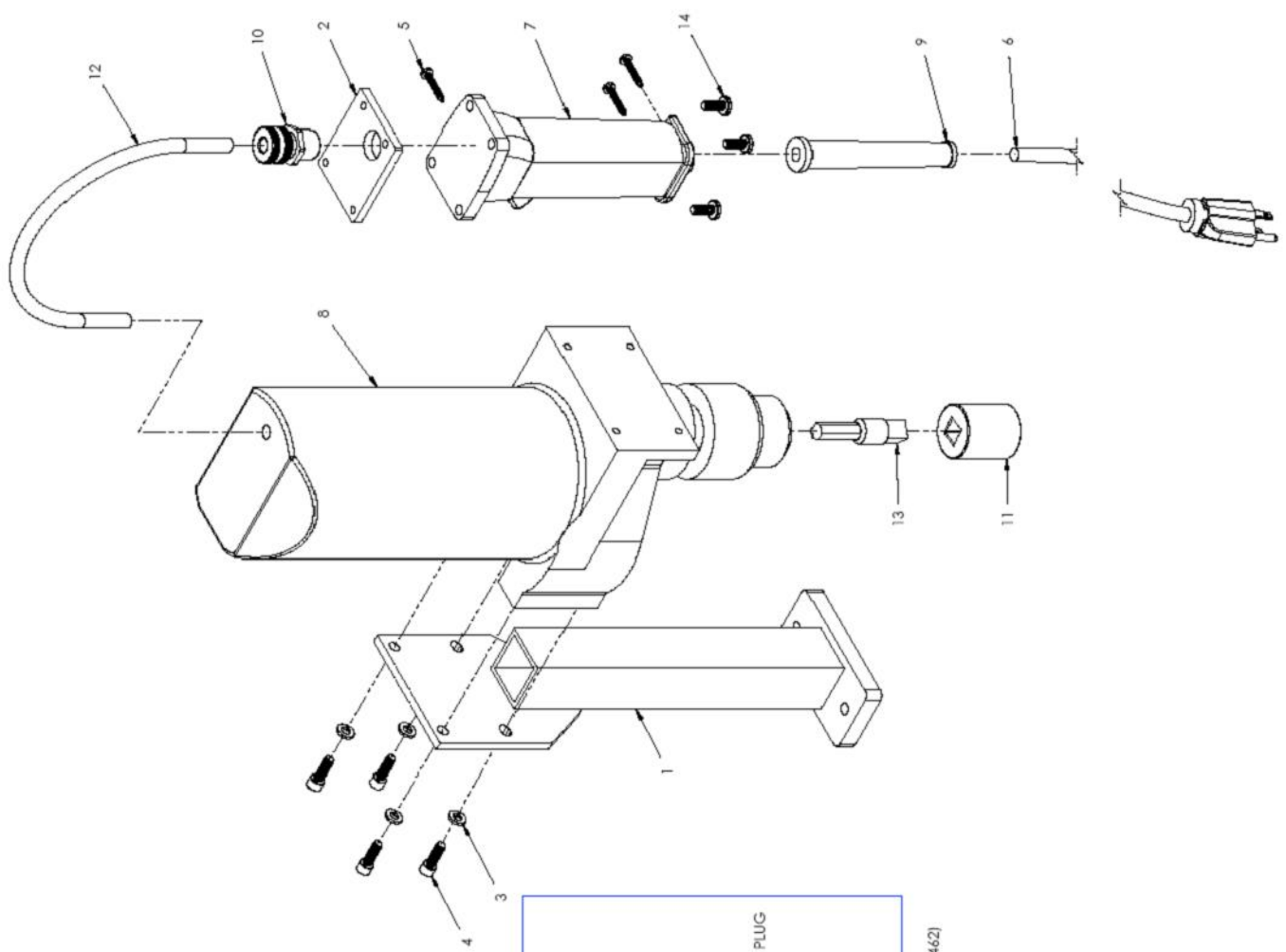

SWITCH WIRE DIAGRAM (HANDLE/SWITCH KIT #277147)

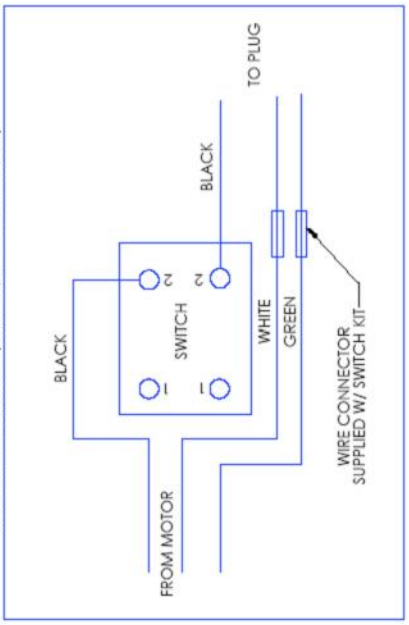

SWITCH WIRE DIAGRAM (TYCO ONE PIECE MOLDED SWITCH #275462)

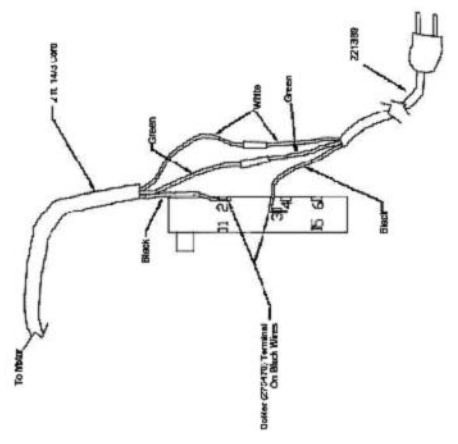

ITEM NO.	PART NUMBER	DESCRIPTION	QTY
1	700457	MOTOR MOUNT ASSEMBLY	1
2	700532	PLATE	1
3	275105	1/4" SPLIT LOCK WASHER	4
4	4181	1/4-20 x 3/4" SHCS	4
5	276804	8-16 x 1 SLOTTED TORX HEAD 06-82-7326	3
6	221389	CORD SET	1
7	277147	HANDLE & SWITCH KIT	1
8	275466	MILWAUKEE DRILL MOTOR 4262-1	1
9	276820	CORD PROTECTOR 44-76-0140	1
10	275716	CORD CONNECTOR	1
11	275494	1" IMPACT SOCKET	1
12	276553	2' 14-3 ELECTRICAL CORD	1
13	275576	ADAPTER	1
14	276575	1/2-20 x 5/8" PAN HEAD SCREW	4
15	275782	RING TERMINAL C 01 411X **NOT SHOWN**	3
16	276787	CRIMP CONNECTOR **NOT SHOWN**	2